



Standard Test Method for Shock Testing of Structural Insulation of A-Class Divisions Constructed of Steel or Aluminum¹

This standard is issued under the fixed designation F2877/F2877M; the number immediately following the designation indicates the year of original adoption or, in the case of revision, the year of last revision. A number in parentheses indicates the year of last reapproval. A superscript epsilon (ε) indicates an editorial change since the last revision or reapproval.

^{ε1} NOTE—Editorially corrected the designation to reflect dual units of measurement statement (1.5) in October 2013.

INTRODUCTION

Passive fire protection materials have been required and used on commercial ships for decades. The passive systems include the non-combustible insulation material and its means of attachment to steel or aluminum divisions. The passive system has been evaluated in a standard fire test using a standard steel or aluminum structural core. No impact loading has been required prior to testing for fire resistance.

The United States Navy requires shock testing of passive fire protection prior to fire resistance testing; this test is defined in MIL-STD-3020, Fire Resistance of U.S. Naval Surface Ships, 7 November, 2007. The technology to economically shock test the passive fire protection systems was developed 50 years ago, and equipment in commercial laboratories is available.

After the terrorist attack on September 11, 2001 it is our responsibility that we add a level of shock protection to our passive fire protection systems on commercial ships where appropriate.² Many of the passive fire protection systems used today are mechanically fastened and will perform the intended function after a shock event.

Passive fire protection insulation may have thermal or acoustic treatments added to the insulated division. These treatments add mass to the fire protection system and their effect on shock is not included in this specification.

TABLE OF CONTENTS

	Introduction
Section 1	Scope
Section 2	Referenced Documents
Section 3	Terminology
Section 4	Significance and Use
Section 5	Shock Test Prior to Fire Resistance Test
Section 6	Criteria to Evaluate Shock Test Specimen
Section 7	Post Shock Fire Resistance Test
Section 8	Criteria to Evaluate the Fire Resistance of the Shock Test Specimen
Section 9	Test Report
Section 10	Precision and Bias
Section 11	Key Words

1. Scope

1.1 The purpose of the specification is to evaluate insulation installed on steel or aluminum structural division as defined in

¹ This test method is under the jurisdiction of ASTM Committee F25 on Ships and Marine Technology and is the direct responsibility of Subcommittee F25.02 on Insulation/Processes.

Current edition approved May 1, 2013. Published May 2013. Originally approved in 2011. Last previous edition approved in 2011 as F2877 – 11^{ε1}. DOI:10.1520/F2877-13E01.

² JOM, 53(12), 2001 pp 8-12 and www.nist.gov/public.affairs/releases/wtc-briefing-april0505.htm

IMO resolution A.754 (18) to ensure the insulation is not degraded in the event of a shock.

1.2 The non-combustible passive fire protection insulation shall be installed, which will meet the highest level of commercial fire resistance expected. Lower levels of fire resistance will be allowed without additional shock testing.

1.3 This test method is used to measure and describe the response of materials, products, or assemblies to heat and flame under controlled conditions, but does not by itself incorporate all factors required for fire-hazard or fire-risk assessment of the materials, products or assemblies under actual fire conditions.

1.4 Fire testing is inherently hazardous. Adequate safeguards for personnel and property shall be employed in conducting these tests.

1.5 The values stated in either SI units or inch-pound units are to be regarded separately as standard. The values stated in each system may not be exact equivalents; therefore, each system shall be used independently of the other. Combining values from the two systems may result in non-conformance with the standard.

1.6 *This standard does not purport to address all of the safety concerns, if any, associated with its use. It is the responsibility of the user of this standard to establish appropriate safety and health practices and determine the applicability of regulatory limitations prior to use.*

2. Referenced Documents

2.1 ASTM Standards:³

[E176 Terminology of Fire Standards](#)

2.2 International Maritime Code: International Code for Application of Fire Test Procedures, ISBN 92-801-1452-2⁴:

[A.754 \(18\) Recommendation on Fire Resistance Tests for “A,” “B,” and “F” Class Divisions](#)

2.3 United States Military Documents:

[MIL-S-901D Requirements for Shock Tests H.I. \(High Impact\) Shipboard Machinery, Equipment, and Systems⁵](#)

[NAVSEAINST 9491.ID Approved Class HI Shock Testing Machines⁶](#)

[MIL-STD-3020 Fire Resistance of U.S. Navy Surface Ships⁷](#)

3. Terminology

3.1 Refer to Terminology [E176](#) for general terms associated with fire issues.

3.2 Definitions:

3.2.1 *A-Class division*—“A” class divisions in accordance with Part 3 of IMO FTP Code are those divisions formed by bulkheads and decks which comply with the following criteria:

(a) They are constructed of steel or other equivalent material;

(b) They are suitably stiffened;

(c) They are insulated with approved non-combustible materials such that the average temperature of the unexposed side will not rise more than 140°C above the original temperature, nor will the temperature, at any one point, including any joint, rise more than 180°C above the original temperature, with the time listed below:

class “A-60”	60 min
class “A-30”	30 min
class “A-15”	15 min
class “A-0”	0 min

(d) They are so constructed as to be capable of preventing the passage of smoke and flame to the end of the one-hour standard fire test; and

(e) The Administration required a test of a prototype bulkhead or deck in accordance with the Fire Test Procedures Code to ensure that it meets the above requirements for integrity and temperature rise.

3.2.2 *fire resistance, n*—the ability of a material, product, or assembly to withstand fire or give protection from it for a period of time.

3.2.2.1 *Discussion*—Fire resistance is the ability of a division or boundary (typically a bulkhead or overhead) to withstand fire, give protection from it, prevent fire spread to adjoining compartments, and retain structural integrity under fire. Structural integrity is the ability to continue to carry a structural load. Fire resistance does not address reaction to fire properties such as ignitability, surface flame spread, heat release rates, smoke density, fire gas toxicity, or other material fire performance limits.

3.2.2.1 *fire resistance rating*—a measure of the elapsed time during which a material, product, or assembly continues to exhibit fire resistance under specified exposure conditions.

3.2.2.2 *restricted application*—when a division will only protect against a fire threat with the insulation installed on the fire side only, the division is designated as fire resistant with restricted application.

3.2.2.3 *un-restricted application*—when a division is protected against a fire threat from both sides, the division is designated as fire resistant with unrestricted application.

3.2.3 *non-combustible insulation*—an insulation material when tested in accordance with the FTP Code, Annex 1, Part 1, and meet the acceptance criteria are non-combustible.

3.2.4 *standard steel or aluminum structural core*—a structural core used to construct the test specimen. It is constructed of either steel or aluminum with the dimensions and stiffeners shown in [Figs. 1-4](#).

4. Significance and Use

4.1 This test method evaluates the ability of a non-combustible passive fire protection system installed on structural divisions on commercial ships to function after shock loading.

³ For referenced ASTM standards, visit the ASTM website, www.astm.org, or contact ASTM Customer Service at service@astm.org. For *Annual Book of ASTM Standards* volume information, refer to the standard’s Document Summary page on the ASTM website.

⁴ Available from IMO Publishing Service, 4 Albert Embankment, London SE1 7SR, United Kingdom, email: publication-sales@imo.org

⁵ Available on the internet at www.dtbtest.com/PDFS/MIL-S-901D.pdf 5 6

⁶ Available on the internet at [nsdb.navsses.navy.mil/Approved %20Class%20HI%20Shock%20Testing%20Machines.pdf](http://nsdb.navsses.navy.mil/Approved%20Class%20HI%20Shock%20Testing%20Machines.pdf)

⁷ Available on the internet at www.dtbtest.com/PDFS/MIL-S-901D.pdf

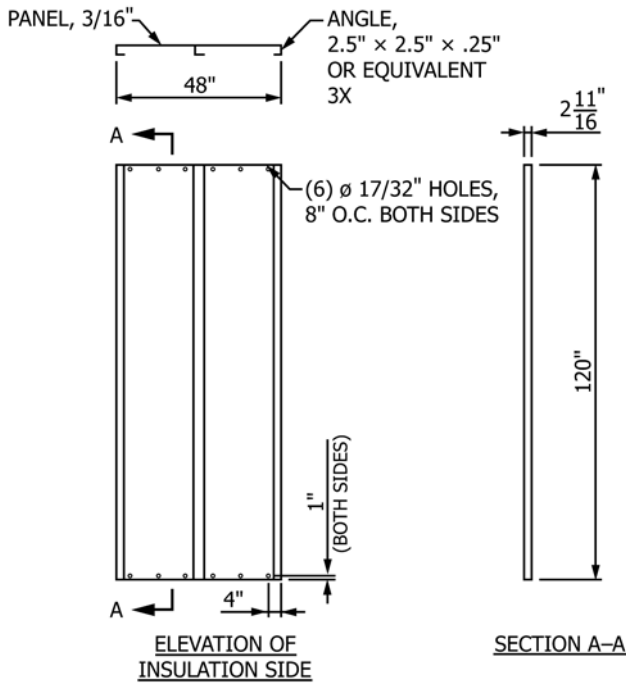

FIG. 1 Steel Test Specimen Construction Details for A-Class Bulkhead

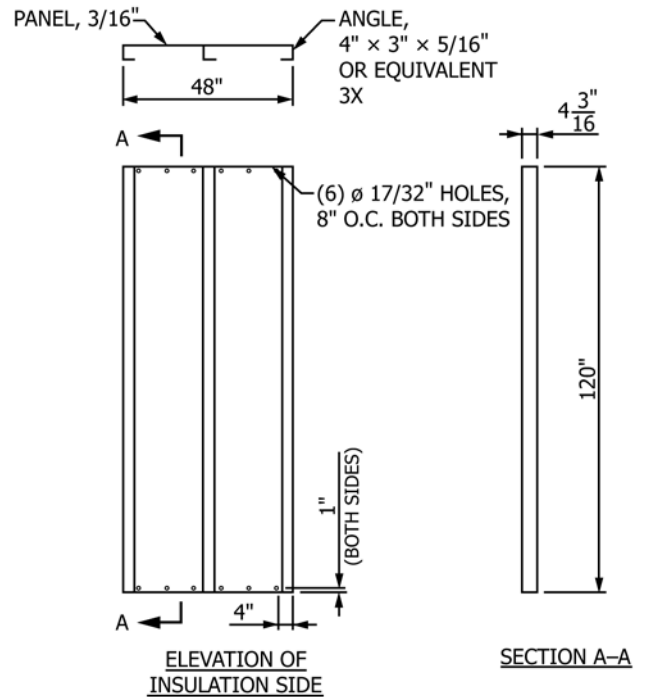

FIG. 3 Steel Test Specimen Construction Details for A-Class Deck

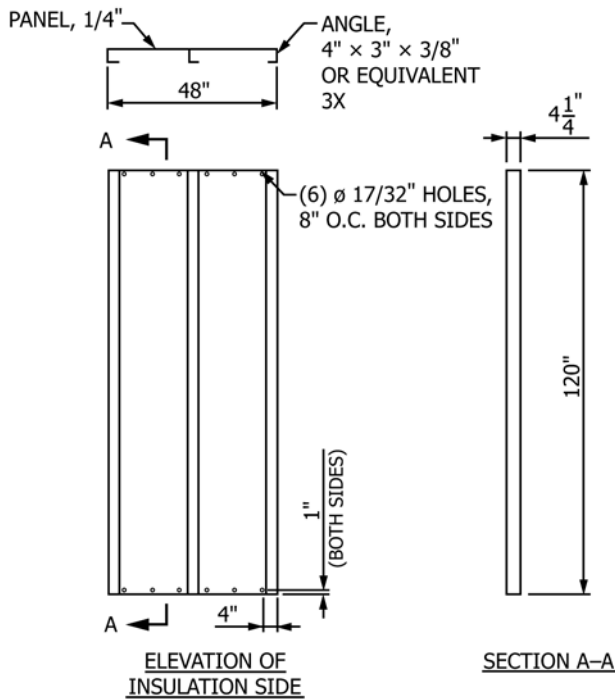

FIG. 2 Aluminum Test Specimen Construction Details for A-Class Bulkhead

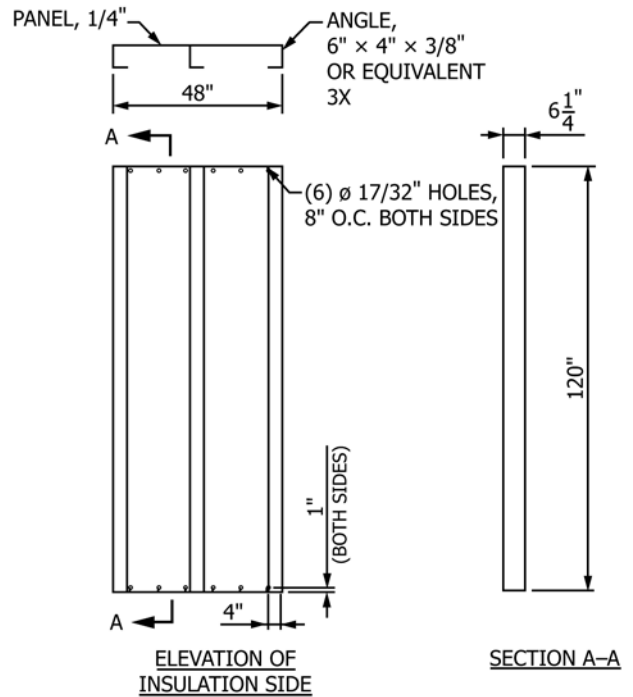

FIG. 4 Aluminum Test Specimen Construction Details for A-Class Deck

4.2 The shock loading is accomplished by conducting impact testing of a test specimen consisting of insulation on a standard steel or aluminum structural core installed on a medium weight shock test machine.

4.3 Following the shock testing the shocked test specimen and an unshocked test specimen are tested for fire resistance. Both shocked and unshocked test specimens are installed side-by-side in a fixture and fire tested at the same time.